

# Type HR High Resistance Grounding Systems

## APPLICATION

Powerohm Type HR High Resistance Grounding Systems are an economical means of improving a three-phase ungrounded power system by providing the following advantages:

**System Protection:** Offers protection by providing a ground-to-neutral connection for a three-phase power system, while still allowing to operate as an "ungrounded system." When the neutral of a system is not grounded, the system is vulnerable to potentially damaging ground faults.

**Transient Overvoltage Reduction:** A high resistance grounding system reduces the magnitude of high transient overvoltages appearing during normal switching of a circuit having a ground fault. High transient overvoltages may cause failure of equipment or insulation at locations on the system other than at the point of the fault.

**Ground Fault Detection Warning:** Instantly provides a warning when the first ground fault occurs through an alarm signal. An optional audible horn or red warning beacon is available.

**Ground Fault Location Simplified:** A pulsing contactor allows the ground fault location to be quickly located by use of a portable clamp-on current detector. The ease and swiftness of ground fault location eliminates the need to trace faults by opening and closing secondary feeders, branch circuits and individual loads one at a time.

**Uninterrupted Service:** A single line-to-ground fault left in operation may result in a second ground fault. If a second fault occurs on another phase before the first is removed, considerable damage may be caused by the relatively high line-to-line fault current. The potential for quickly locating and removing faults before damage occurs to critical processes minimizes outages, and costly manufacturing shutdowns.

**Improved Personnel Safety:** Reducing transient overvoltages, equipment arcing, fault levels, insulation failures and fault tracing through circuit isolation schemes decreases hazards to personnel.

## DESIGN REQUIREMENTS

**System Type and Voltage:** Standard high resistance grounding systems are available for both wye and delta systems (50 or 60 hertz). Standard units are rated for system voltages of 240, 480, 600, 2400, 3300 and 4160 volts.

**Current Rating:** Type HR grounding systems are available with standard current ratings ranging between 1 and 10 amps. Taps are provided to adjust current above the maximum system charging currents.

## High Resistance Grounding System



**Safety Enclosures:** Our high resistance grounding units are available in grounded safety enclosures with ratings of NEMA 1, 3R and 12. Standard low voltage units (600 volts or less) are installed in a wall-mounted enclosure with a floor-mounted enclosure as an option. Medium voltage units (2400 volts or higher) are available in a floor-mounted enclosure only. The standard finish is ANSI 61 grey.

**Resistor Assembly:** The resistor assembly is normally installed on top of our wall mounted or freestanding enclosures. Standard units consist of either wirewound or edgewound elements assembled with all stainless steel hardware in a screened or louvered enclosure. In some cases, optional provisions can be made to house resistors in remote enclosures or inside floor-mounted enclosures.

**Options:** A number of additional options are available to meet your special application. Contact the factory with your requirements or specification.



5713 13th Street  
Katy, Texas 77493  
Phone: (281) 391-6800, Fax: (281) 391-6810  
Please visit our website at [www.powerohm.com](http://www.powerohm.com)

# 2400, 3300 & 4160 Volt Wye or Delta Systems

## OPERATION DESCRIPTION

**Normal Operation:** Under normal operating conditions, when there is no ground fault present on the system and no current flowing through the resistor. An illuminated green indicating light, located on the front door, verifies normal operating conditions and proper control power.

**Ground Fault Condition:** During a ground fault condition a red indicating light, located on the front door, will illuminate and the alarm contacts will activate. The red indicating light and the alarm contacts will remain activated until the ground fault is removed. During a ground fault, voltage will appear across the resistor. The resistor includes multiple taps to adjust the fault current to a value slightly greater than the system magnetizing current. The resistance taps can be factory set or adjusted at time of equipment installation.

**Ground Fault Location:** To locate the ground fault, simply activate the pulse contactor by turning the selector switch, located on the front door, from the "Normal" position to the "Pulse" position. This activates a cycle of 40 pulses per minute to alternate the ground fault current between the set magnitude and zero. Maintenance personnel can then use a portable clamp-on ammeter to follow the fluctuating fault current through the system to the location of the fault source. After removing the ground fault, the selector switch is reset to stop the pulsing cycle. The green indicating light should illuminate to indicate that the system has returned to normal.

## FLOOR-MOUNTED DIMENSIONS

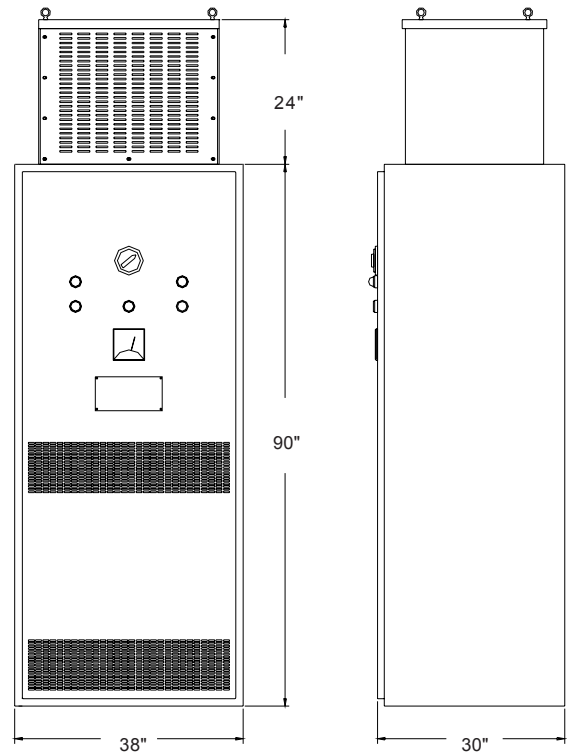

**STANDARD NEMA 1 FLOOR-MOUNTED ENCLOSURE (NEMA 12 AND 3R HEIGHTS INCREASE BY 6 INCHES)**

## MEDIUM VOLTAGE WYE SYSTEMS

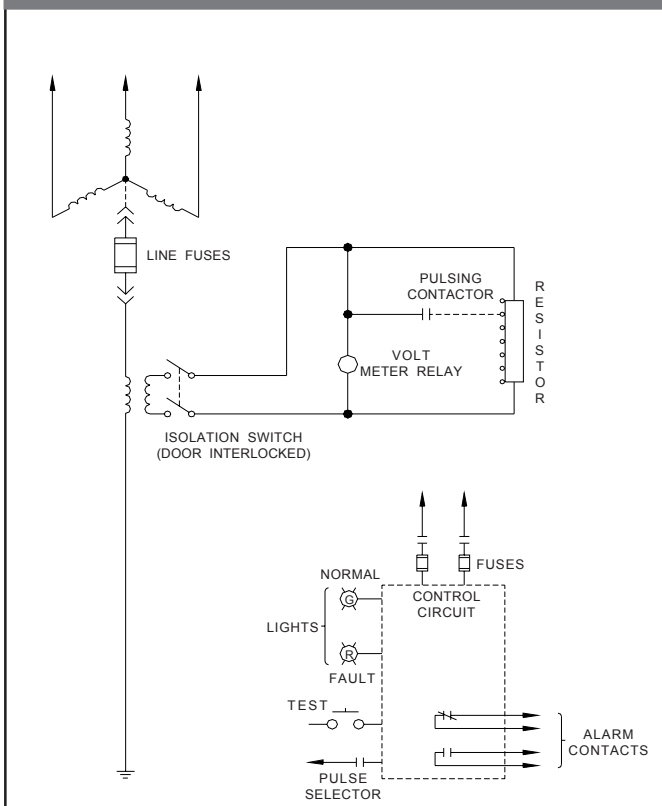

## MEDIUM VOLTAGE DELTA SYSTEMS

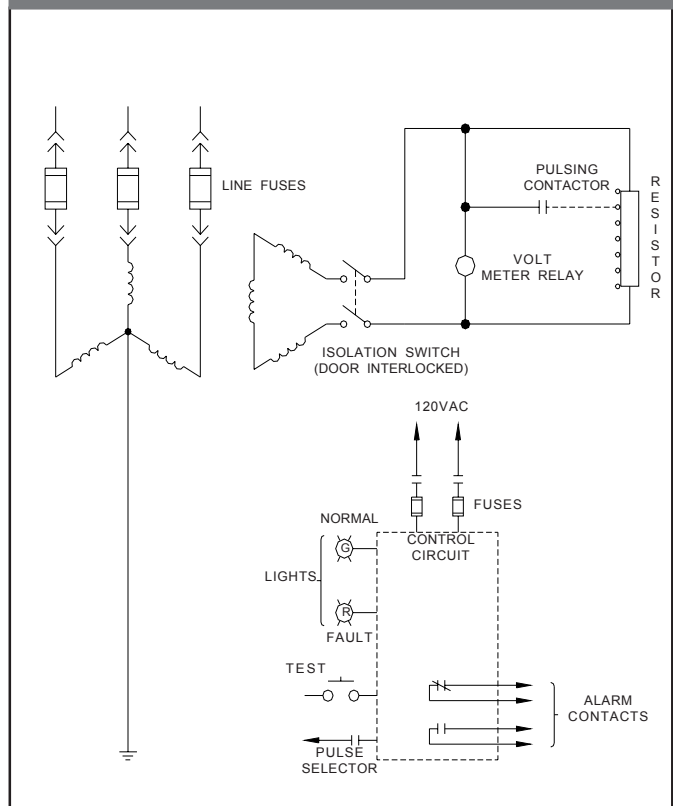

# 240, 480 and 600 Volt Wye or Delta Systems

## OPERATION DESCRIPTION

Powerohm's low and medium voltage units both have the same operating instructions. The overall size and layout is different, but the indicating lights and controls on the front door remain the same. Refer to the previous section for details.

## WALL-MOUNTED DIMENSIONS

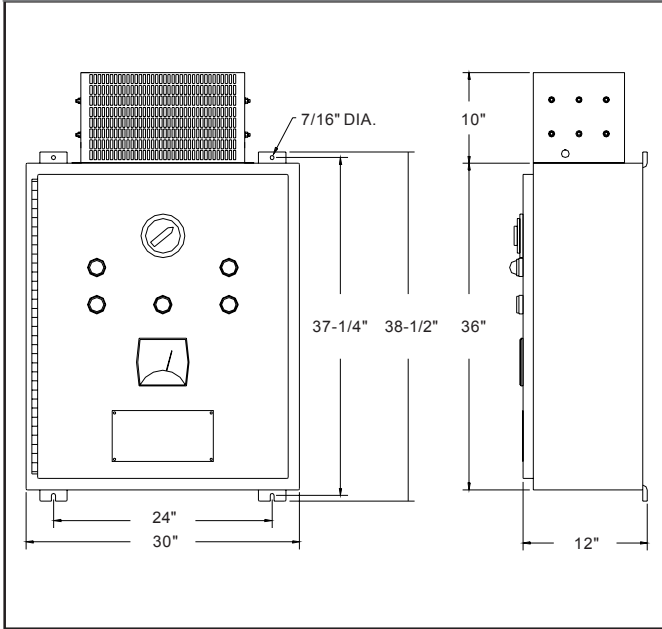

## FLOOR-MOUNTED DIMENSIONS

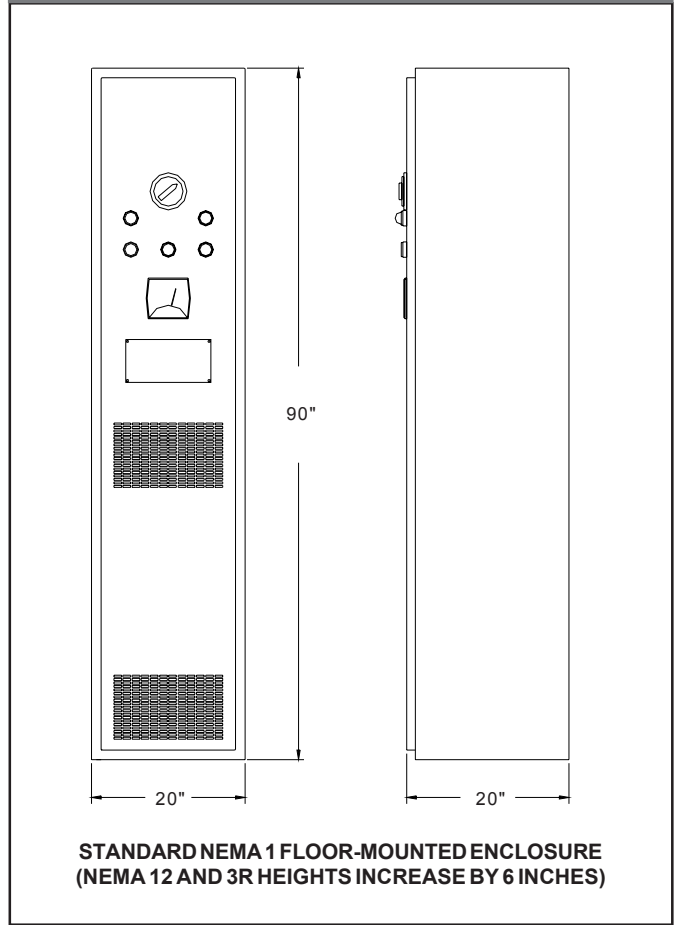

## LOW VOLTAGE WYE SYSTEMS

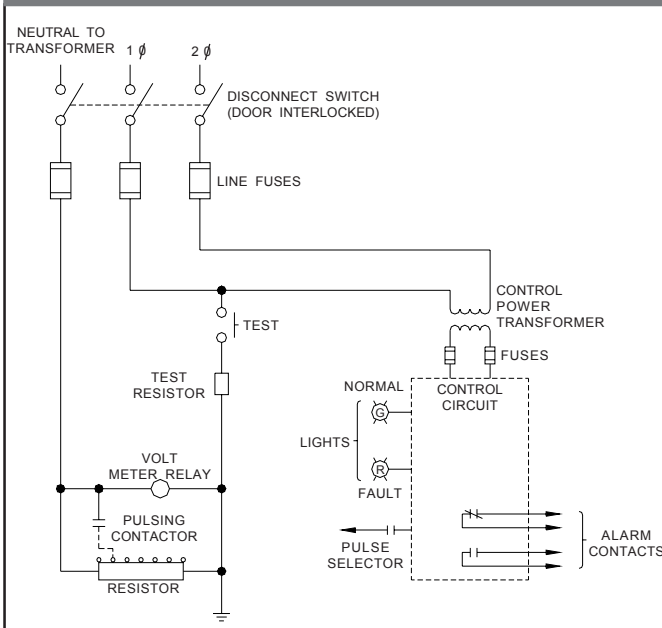

## LOW VOLTAGE DELTA SYSTEMS

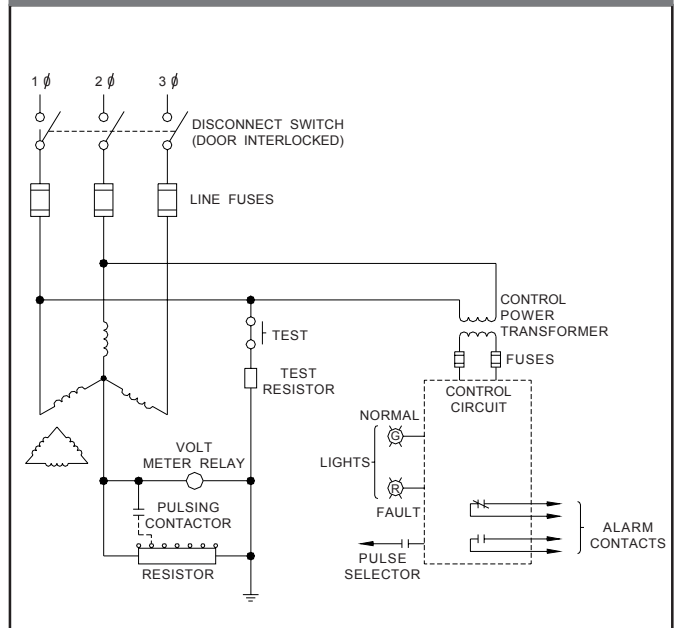

# Type HR Equipment Specifications & Part Numbers

**SPECIFY PART NUMBERS AS FOLLOWS:** HR \_\_\_\_\_

<b>SYSTEM VOLTAGE</b>						
240 volt	1					
480 volt	2					
600 volt	3					
2400 volt	4					
3300 volt	5					
4160 volt	6					
<b>SYSTEM TYPE</b>						
Wye, 50 hertz		W5				
Wye, 60 hertz		W6				
Delta, 50 hertz		D5				
Delta, 60 hertz		D6				
<b>GROUND FAULT CURRENT</b>						
1-6 Amps			A			
2-7 Amps			B			
2-10 Amps			C			
<b>ENCLOSURE STYLE</b>						
Wall-mounted (600V or less)				W		
Floor-mounted				F		
<b>ENCLOSURE TYPE</b>						
NEMA 1					N1	
NEMA 12					N2	
NEMA 3R					N3	
<b>RESISTOR LOCATION</b>						
Remote (for installing in an isolated area)						R
Internal (available for low voltage, floor-mounted units only)						S
Top-mounted (resistors are shipped separately with floor-mounted models)						T

## AVAILABLE OPTIONS

Timing Relay - add "1" to P/N  
 Undervoltage Relay - add "2" to P/N  
 Ammeter with CT - add "3" to P/N  
 Red Warning Beacon - add "4" to P/N  
 Audible Horn with Shutoff - add "5" to P/N  
 Without Pulsing Contactor - add "6" to P/N

For example, the part number for a 2400 volt wye system, 60 Hertz, 2-7A, installed in a wall-mounted, NEMA 1 enclosure with a remote resistor, timing relay, and red warning beacon is HR4W6B-WN1R14.

Ground Fault Detector - A portable clamp-on ammeter w/ case; specify P/N HR5-GFD.

## STANDARD LOW VOLTAGE SPECIFICATION

Qty.	Description (Wye and Delta Systems)
1	Wall-mounted enclosure (an optional floor-mounted enclosure is available).
1	Grounding resistor with multiple taps
1	Disconnect switch interlocked with door.
3	Line fuses
1	Repeat cycle timer (set at 40 pulses per minute)
1	Volt meter relay (2 setpoints)
1	General purpose relay (alarm contacts)
3	Neutral deriving transformer (delta system only)
1	Control power transformer
1	Green indicating light (Normal)
1	Red indicating light (Ground Fault)
1	Selector switch (Normal-Pulse)
2	Pushbutton (Test, Reset)
1	Test resistor
1	Sequence of operation nameplate

Note: Control power obtained from system

## STANDARD MEDIUM VOLTAGE SPECIFICATION

Qty.	Description (Wye and Delta Systems)
1	Floor-mounted enclosure
1	Grounding resistor with multiple taps
1	Isolation switch (fused & door interlocked)
1	Repeat cycle timer (set at 40 pulses per minute)
1	Volt meter relay (2 setpoints)
1	General purpose relay (alarm contacts)
1	Grounding Transformer (3 for delta systems)
1	Control power switch
2	Control power fuses
1	Green pilot light (Normal)
1	Red pilot light (Ground Fault)
1	Selector switch (Normal-Pulse)
2	Pushbutton (Test, Reset)
1	Sequence of operation namplate

Note: 120VAC control power required

**24 HOUR EMERGENCY SERVICE (800) 838-4694**